

R10CS2

Pressure reducing valve in AISI 316L



DESCRIPTION

Self-actuated reducing valves manage downstream pressure without requiring pneumatic or electrical control elements. Pressure is controlled by a balanced piston and shutter, ensuring precision and repeatability of regulation.

Body and inner parts are made of 316L stainless steel with excellent corrosion resistance. Panel mounting with bracket available. Device can be supplied with relieving function. Degreased for oxygen use and pure gases versions available.

Applications: pneumatics, industry, pharmaceutical, chemical, oil & gas, energy and food.

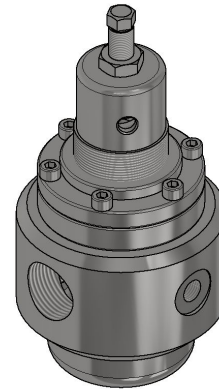

TECHNICAL DATA

MAXIMUM INLET PRESSURE	Threaded version 60 bar Flanged version as per specific standard
SETTING RANGE	0,3 → 3 bar • 0,8 → 8 bar • 1,5 → 15 bar 3 → 30 bar • 5 → 50 bar
IN/OUT CONNECTIONS	3/4" • 1" (G-F / NPT-F) Flanged (UNI EN 1092-1 // ASME B16.5) Clamp (upon request)
GAUGE CONNECTIONS	1/4" G-F
KV (CEI EN 60534-2)	8,5 m ³ /h
MATERIAL	Body - AISI 316L Inner parts - AISI 316L
TEMPERATURE	-25°C → +200°C FPM -40°C → +175°C EPDM Other temperatures upon request
FLUIDS	Gases • Liquids
WEIGHT	4,5 kg (threaded version)
CERTIFICATES	PED 2014/68/UE
ACCESSORIES	Gauge • Bracket
SPARE PARTS KIT	Wear parts

DIMENSIONAL DRAWINGS

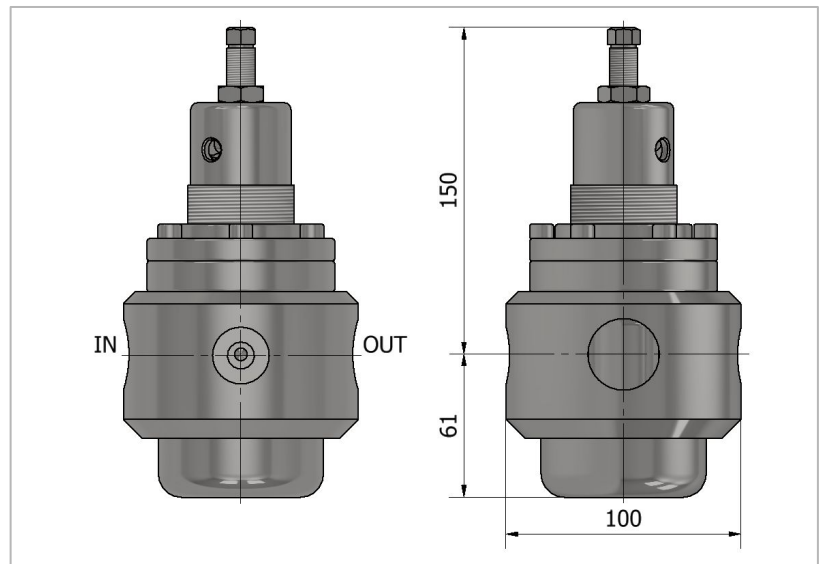

FLOW CHARTS

