

R12CS3

Third stage pressure reducing valve in AISI 316L



DESCRIPTION

Third stage pressure reducing valves find application in systems that require downstream pressure control in mbar.

Pressure is controlled by a diaphragm and a balanced shutter, ensuring precision and repeatability of regulation.

Body and inner parts are made of 316L stainless steel with excellent corrosion resistance.

Panel mounting with bracket available.

Degreased for oxygen use and pure gases versions available.

Applications: pneumatics, industry, pharmaceutical, chemical, oil & gas, energy and food.

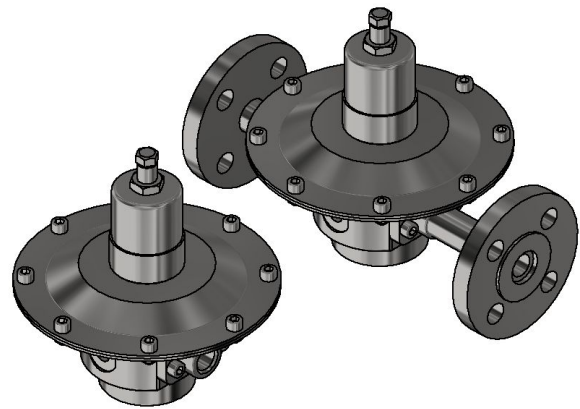

TECHNICAL DATA

MAXIMUM INLET PRESSURE	10 bar
SETTING RANGE	5 → 50 mbar • 20 → 1000 mbar
IN/OUT CONNECTIONS	1/4" • 3/8" • 1/2" (G-F / NPT-F) Flanged (UNI EN 1092-1 // ASME B16.5) Clamp (upon request)
GAUGE CONNECTIONS	1/4" G-F
KV (CEI EN 60534-2)	1,5 m3/h
MATERIAL	Body - AISI 316L Inner parts - AISI 316L
TEMPERATURE	-25°C → +130°C Other temperatures upon request
FLUIDS	Gases
WEIGHT	2,6 kg (threaded version)
CERTIFICATES	PED 2014/68/UE • ATEX 2014/34/EU
ACCESSORIES	Gauge • Bracket
SPARE PARTS KIT	Wear parts

DIMENSIONAL DRAWINGS

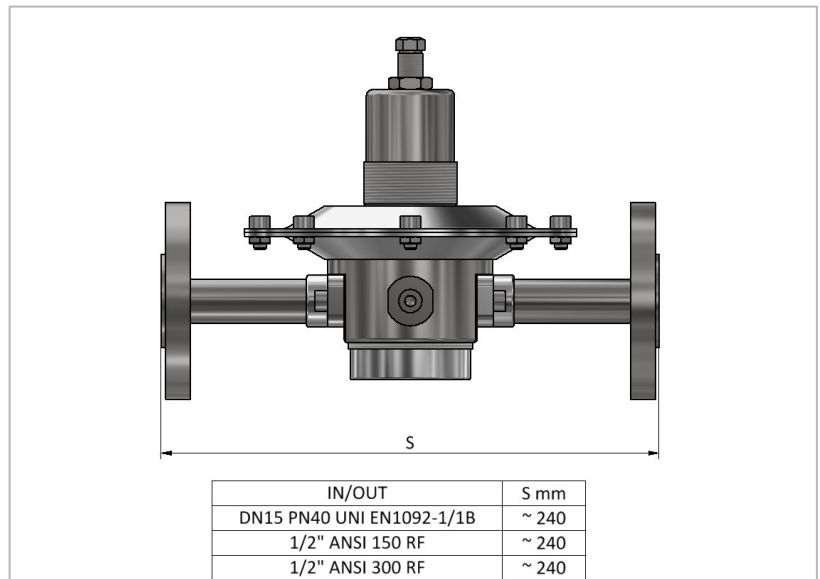
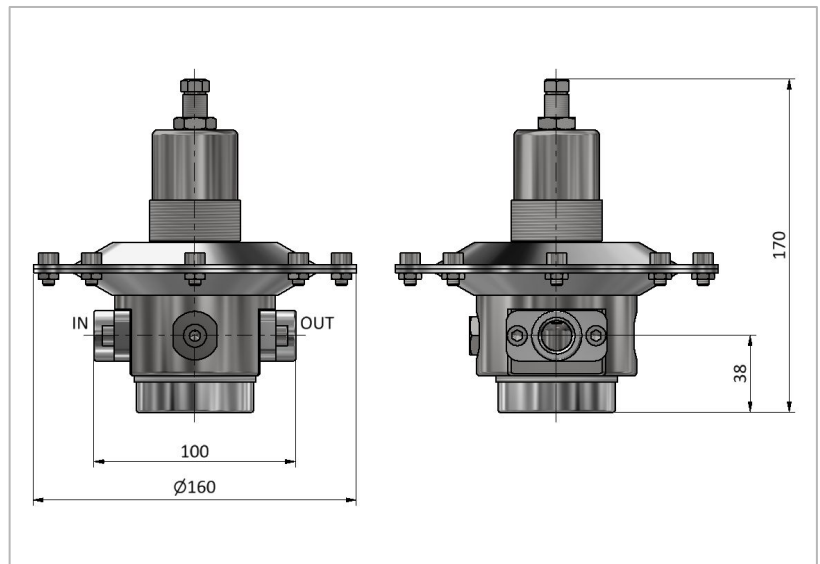

FLOW CHARTS

