

R10BS2

Pressure reducing valve in brass



DESCRIPTION

Self-actuated reducing valves manage downstream pressure without requiring pneumatic or electrical control elements. Pressure is controlled by a diaphragm or a piston that, together with a balanced shutter, ensure precision and repeatability of regulation. Body and inner parts are made of brass with excellent mechanical resistance. Panel mounting with bracket available. Device can be supplied with relieving function. Degreased for oxygen use and pure gases versions available.

Applications: automotive, pneumatics and industry.

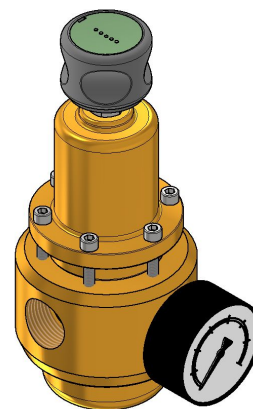

TECHNICAL DATA

MAXIMUM INLET PRESSURE	60 bar
SETTING RANGE	0,2 → 3 bar • 0,5 → 8 bar • 1,5 → 15 bar 2 → 30 bar • 3 → 50 bar
IN/OUT CONNECTIONS	3/4" • 1" (G-F / NPT-F)
GAUGE CONNECTIONS	1/4" G-F
KV (CEI EN 60534-2)	8,5 m3/h
MATERIAL	Body - brass Inner parts - brass
TEMPERATURE	-20°C → +80°C Other temperatures upon request
FLUIDS	Gases • Liquids
WEIGHT	4,3 kg
CERTIFICATES	PED 2014/68/UE
ACCESSORIES	Gauge • Bracket
SPARE PARTS KIT	Wear parts

DIMENSIONAL DRAWINGS

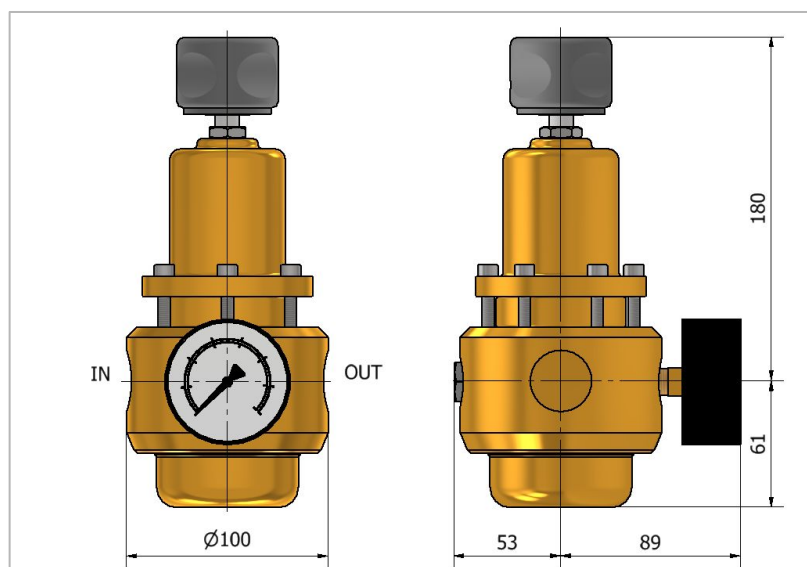

FLOW CHARTS

